

Ultima Shelving

CI-80 Shelving System

Design Manual



PRECISION
BY  **DEXION**

Blank

Ultima Shelving Design Manual



This manual remains the sole property of Dexion Commercial. It must not be copied without prior written consent and must be returned upon request. The information contained within this manual is to be regarded as confidential and must not be disclosed to any third party.

Whilst the utmost care is taken to ensure the accuracy of the data and design details shown within, Dexion cannot, under any circumstances, be held liable for any injuries, expenses or loss which may, in any degree, be attributed to the use or adoption of such data and design details.

Any modification, repair, or alteration of the products described herein by a third party without written approval voids Dexion's warranty obligations.

© Copyright:

Dexion Commercial
25 Peterkin Street
Wingate
Lower Hutt
Wellington 5045

Phone: + 64 4 920 5400
Fax: + 64 4 920 5402

Date of Issue: June 2013

Blank

Ultima Shelving Design Manual

Issue/ Amendment	Date Issued	Description	Notes
Issue 1	Feb 2009	Product Launch (NZ)	

Blank

Ultima Shelving Table of Contents

SECTION 1 PRODUCT INTRODUCTION	1
INTRODUCTION.....	1
PARAMETERS OF THE SYSTEM	2
SECTION 2 COMPONENT DESCRIPTIONS	1
FRAME PANELS	1
BACK PANELS	2
BACK BRACING	3
SHELF.....	4
SHELF CLIPS	5
SHELF STIFFENER	5
KICKPLATE	6
BASEPLATE	7
LEVELLING PLATE	7
FASTENERS.....	8
M6 X 10 COMB SCREW & NUT ZP	8
M6 X 16 SET SCREW AND M6 NYLOC NUT	8
SCREW 8G X 3/8 (10MM) PAN HD SELF TAPPING.....	9
NUT - 8G 'U'	9
FLOOR FIXING	9
REAR COVER	10
FINISHING PANEL.....	11
SECTION 3 DESIGNERS REFERENCE	1
DEFINITIONS	1
GENERAL LAYOUT	3
GENERAL DESIGN RULES AND RECOMMENDATIONS.....	4
ALLOWANCE FOR CREEP	4
LEFT TO RIGHT.....	4
FRONT TO BACK	4
INSTALLATION PLANNING	5
GENERAL	5
SHELF LAYOUT PLAN	5
PLAN BAY LAYOUTS	5
INDIVIDUAL BAY SHELF LAYOUT.....	6
BACK BRACING	7
RACK STABILITY AND FIXING	9
FLOOR FIXING REQUIREMENT	10
FLOOR LEVELLING	11
FLOOR QUALITY	11
SAFETY SIGNAGE.....	11
LOADING INFORMATION.....	12

SHELVES	12
BAYS WITH BACK BRACING	13
BAYS WITH BACK CLADDING	14
BAYS WITH BACK CLADDING AND BOLTED MIDDLE SHELF	15
STANDARD BAY CONSTRUCTION TIMES	16

SECTION 1

PRODUCT INTRODUCTION

INTRODUCTION

Ultima CI-80 is a versatile adjustable, light / medium duty shelving system which can be used to create many styles of storage installation, individually designed and constructed to suit client requirements and site conditions. It is modular in its design and will allow reconfiguration or addition to bays and shelves to best suit the storage needs.

Ultima CI-80 shelving forms part of the Compactus range of commercial shelving products.

Frame Panels

One piece sheet steel rolled upright type frame panels available in a range of depths and heights.

Shelves

Horizontal load-bearing shelves which either clip or bolt fix in place depending on position within the bay, or application. Reinforcing is available where medium to high shelf capacities are required.

Accessories

A range of accessories designed to extend the versatility of the system for both industrial and commercial applications including small parts storage and filing.

Adjustability

The slotted uprights allow shelves to be easily adjusted on a 25mm increment.

Finishes and Colour

Steel components are finished with a polyester powdercoat, 50 microns thick, having a gloss level of approximately 70% measured with a 60° gloss meter. Hardness is a minimum 2H.

A range of standard colours are available.

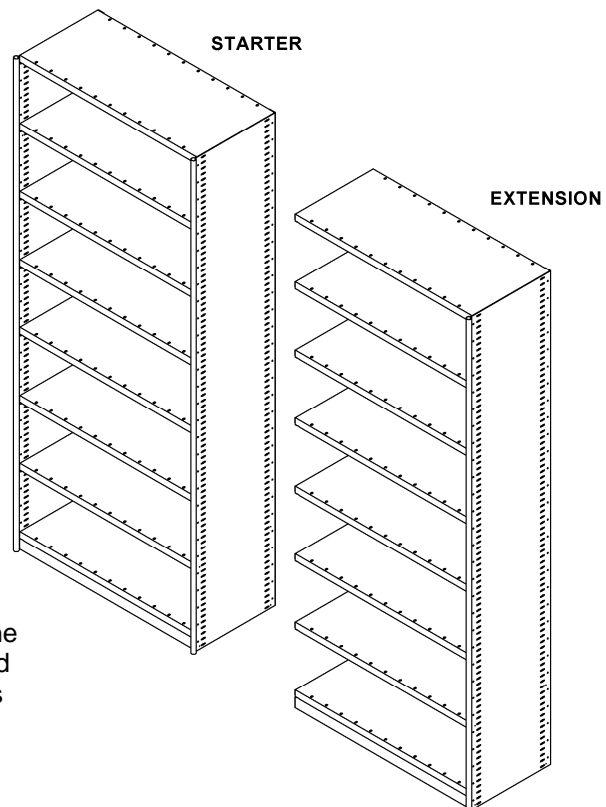

PARAMETERS OF THE SYSTEM

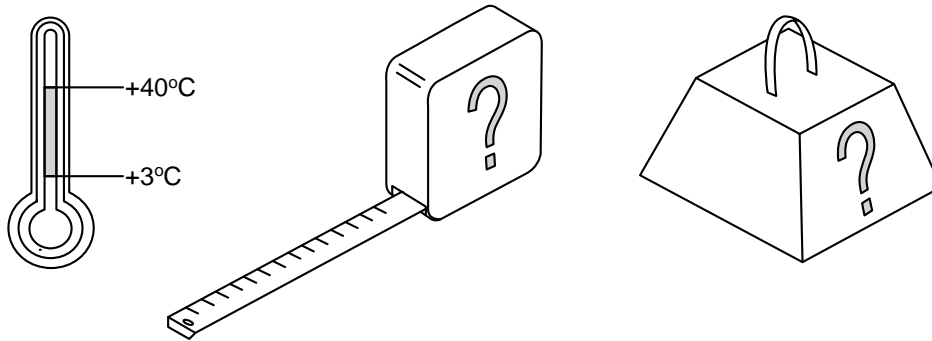

The Ultima CI-80 product has been designed to operate within the following standard parameters.

Floor

Should generally be of a solid concrete construction designed to accept loads imposed by the frame panel. Installations on carpet or similar floor coverings should be mindful of the floor substrate below and that the floor covering will not compress in an uneven manner. Installations on other types of floor, such as timber, bitumen and tarmac, should be specifically designed to suit the strength of the individual floor.

Note: Floor Fixings covered in this manual are suitable for concrete Floors only.

Loads

Individual loads should be stable and self supporting, with a maximum unit weight within the safe working recommendations.

Dry Conditions

Components and load data are based on dry internal applications.

Temperature

+3°C to +40°C.

Applications in Chill and Cold stores with temperatures below +3°C, and where moisture is likely to be present, need to be referred to the Product Support to check suitability of the material finish. Applications in regions of high humidity should be referred to Product Support for suitability of finishes.

Note:

For applications that require operating parameters that are outside those indicated above, please contact Precision for technical guidance on your particular application.

SECTION 2

COMPONENT DESCRIPTIONS

FRAME PANELS

Frame Panels are one piece sheet steel rolled upright type frame panels available in a range of depths and heights

Material	0.75mm high strength steel (300 and 400mm deep) 0.95mm high strength steel (450 and 600mm deep)
Finish	Powder coated
Heights	Standard heights are 1875mm, 2175mm and 2400mm Note: Frame Panels heights are on a 75mm increment
Depths	Standard depths are 300, 400, 450, and 600mm
Adjustability	The shelf clip slot pattern is punched on a 25mm increment

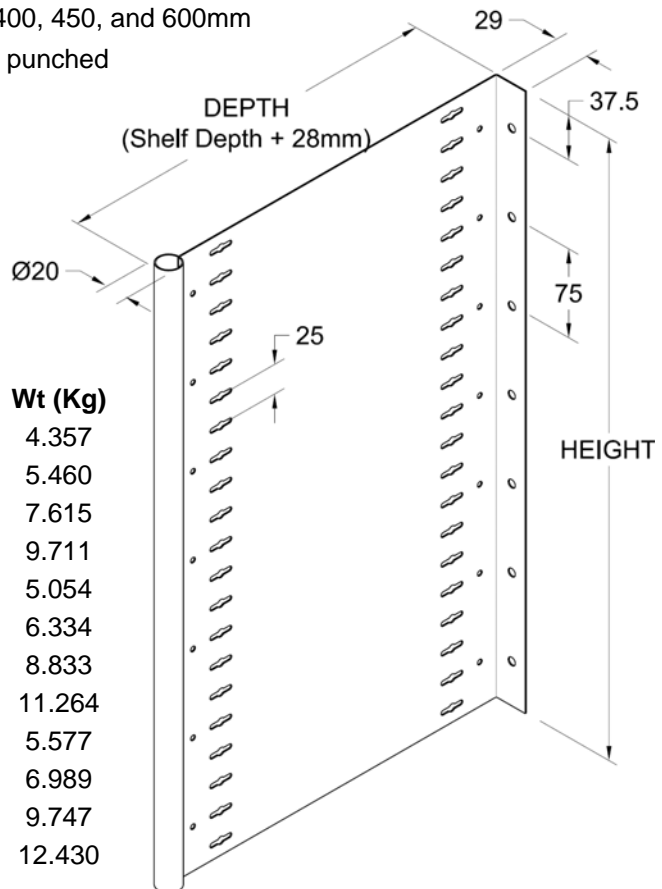

Code	Description	Wt (Kg)
200156	FRAME UL 1875X300	4.357
200161	FRAME UL 1875X400	5.460
200166	FRAME UL 1875X450	7.615
200176	FRAME UL 1875X600	9.711
200206	FRAME UL 2175X300	5.054
200211	FRAME UL 2175X400	6.334
200216	FRAME UL 2175X450	8.833
200226	FRAME UL 2175X600	11.264
200256	FRAME UL 2400X300	5.577
200261	FRAME UL 2400X400	6.989
200266	FRAME UL 2400X450	9.747
200276	FRAME UL 2400X600	12.430

BACK PANELS

Back panels are used to enclose the rear of each bay, and also provide lateral bay bracing. Back bracing can be used as an alternative if bays with open backs are required.

Back cladding is attached to the rear flange of each frame panel using M6x10 Screw & Nuts. Fixings are required in the bottom hole, the top hole, and intermediately on a maximum 300mm pitch (5 holes).

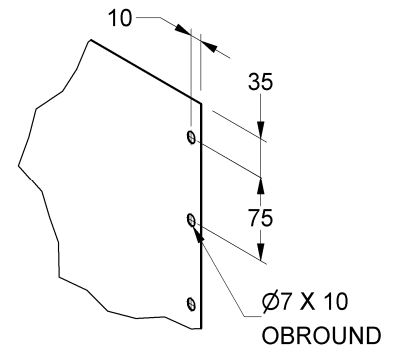

Material	Back Panels are produced from 0.55mm high strength steel.
Finish	Powder coated

Width	'X' (Starter)	'X' (Extension)
750	719	750
900	869	900
1200	1169	1200

Starter Back Panels

Code	Description	Wt (kg)
201561	BACK UL STR 1875X 750	5.970
201566	BACK UL STR 1875X 900	7.180
201576	BACK UL STR 1875X1200	9.600
201581	BACK UL STR 2175X 750	6.928
201586	BACK UL STR 2175X 900	8.332
201596	BACK UL STR 2175X1200	11.141
201601	BACK UL STR 2400X 750	7.662
201606	BACK UL STR 2400X 900	9.215
201616	BACK UL STR 2400X1200	12.321

Extension Back Panels

Code	Description	Wt (kg)
201761	BACK UL EXN 1875X 750	6.212
201766	BACK UL EXN 1875X 900	7.422
201776	BACK UL EXN 1875X1200	9.843
201781	BACK UL EXN 2175X 750	7.209
201786	BACK UL EXN 2175X 900	8.613
201796	BACK UL EXN 2175X1200	11.422
201801	BACK UL EXN 2400X 750	7.973
201806	BACK UL EXN 2400X 900	9.526
201816	BACK UL EXN 2400X1200	12.632

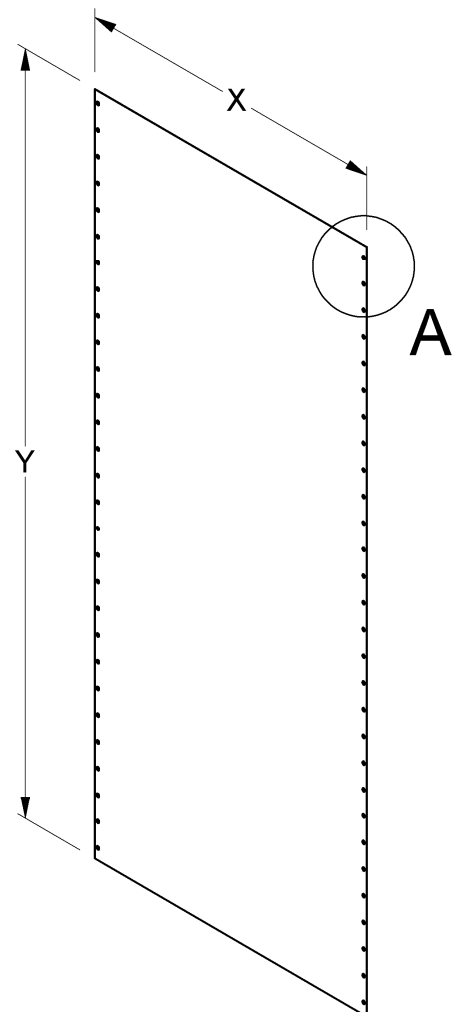

BACK BRACING

Back bracing is used as an alternative method of providing lateral bay bracing when bays with open backs are required.

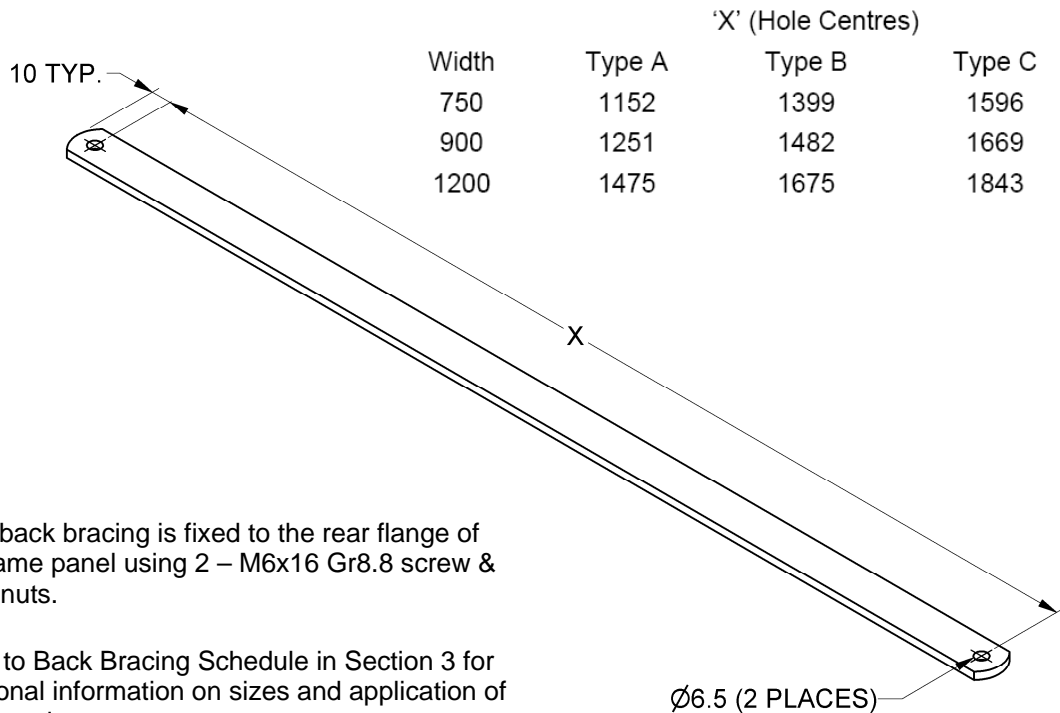

Each back bracing is fixed to the rear flange of the frame panel using 2 – M6x16 Gr8.8 screw & nyloc nuts.

Refer to Back Bracing Schedule in Section 3 for additional information on sizes and application of back bracing.

Material 25 x 3.0mm high strength flat steel
Finish Powder Coated

Code	Description	Wt (kg)
202000	BACK BRACE UL 750A (1152HC)	0.193
202001	BACK BRACE UL 750B (1399HC)	0.234
202002	BACK BRACE UL 750C (1596HC)	0.266
202004	BACK BRACE UL 900A (1251HC)	0.210
202005	BACK BRACE UL 900B (1482HC)	0.248
202006	BACK BRACE UL 900C (1669HC)	0.278
202008	BACK BRACE UL 1050A (1360HC)	0.228
202009	BACK BRACE UL 1050B (1574HC)	0.263
202010	BACK BRACE UL 1050C (1752HC)	0.259
202012	BACK BRACE UL 1200A (1475HC)	0.246
202013	BACK BRACE UL 1200B (1675HC)	0.279
202014	BACK BRACE UL 1200C (1843HC)	0.307

SHELF

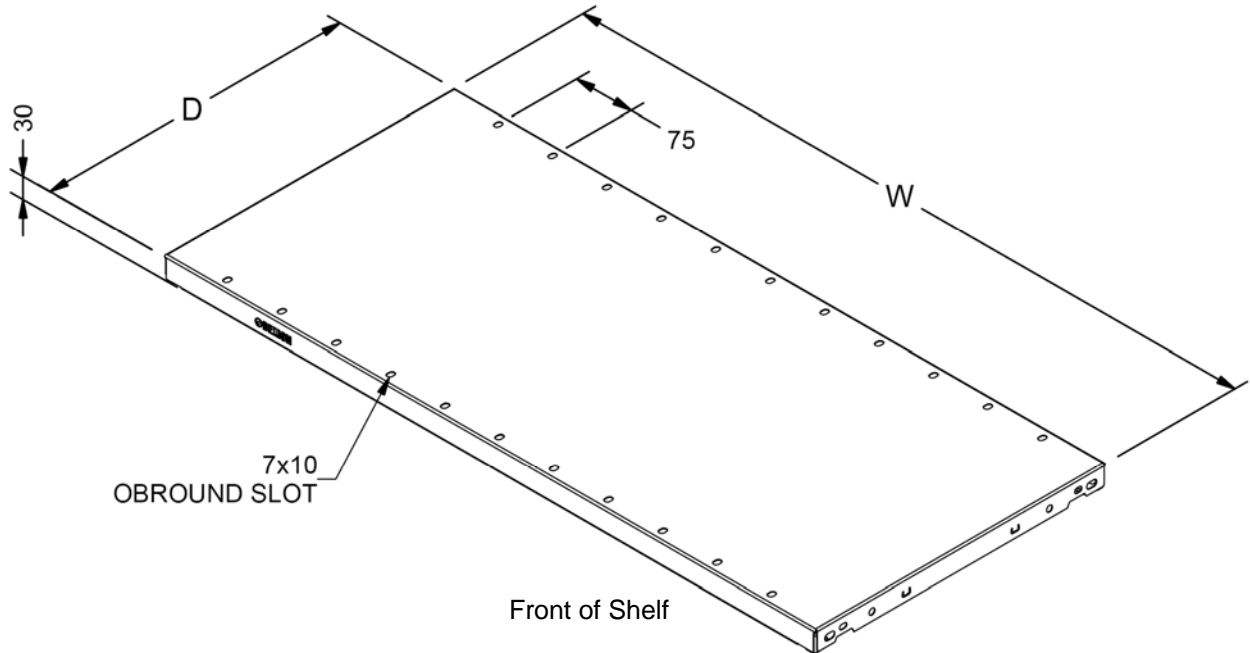

- Material 0.75mm thick high strength steel (shelves up to 450mm deep)
 0.95mm thick high strength steel (shelves 500mm deep and above)
- Finish Powder coated

Note: The shelf should be oriented within a bay so that there are no holes on the visible edge of the shelf

Code	Description	Wt (kg)
201006	SHELF UL 750X300	1.977
201011	SHELF UL 750X400	2.447
201016	SHELF UL 750X450	2.683
201026	SHELF UL 750X600	4.292
201066	SHELF UL 900X300	2.347
201071	SHELF UL 900X400	2.906
201076	SHELF UL 900X450	3.186
201086	SHELF UL 900X600	5.097
201216	SHELF UL 1200X300	3.089
201221	SHELF UL 1200X400	3.824
201226	SHELF UL 1200X450	4.192
201236	SHELF UL 1200X600	6.707

SHELF CLIPS

Shelf clips are used to position the shelf in the bay. All four (4) corners of each shelf must be supported by the shelf clips.



Material 0.8mm spring steel
Finish Zinc Plated

Code Description
151320 SHELF CLIP W TYPE (50 PACK) ZP

Wt (kg)
0.003

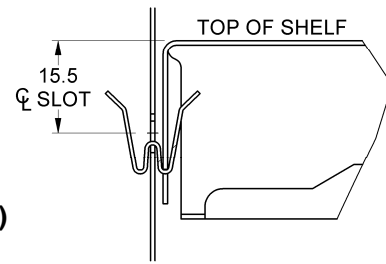

CLIPPED SHELF

SHELF STIFFENER

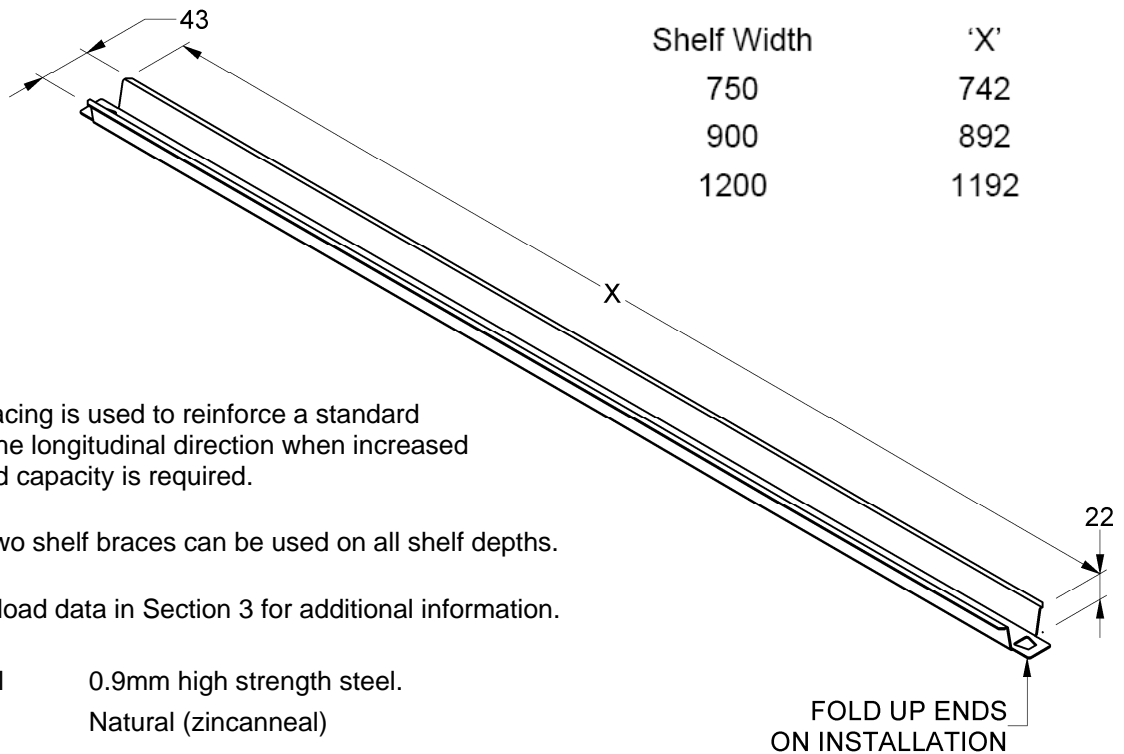

Shelf Bracing is used to reinforce a standard shelf in the longitudinal direction when increased shelf load capacity is required.

One or two shelf braces can be used on all shelf depths.

Refer to load data in Section 3 for additional information.

Material 0.9mm high strength steel.
Finish Natural (zincanneal)

Code Description **Wt (kg)**
201481 SHELF STIFFENER UL 750 ZANN 0.433
201484 SHELF STIFFENER UL 900 ZANN 0.516
201493 SHELF STIFFENER UL 1200 ZANN 0.684

KICKPLATE

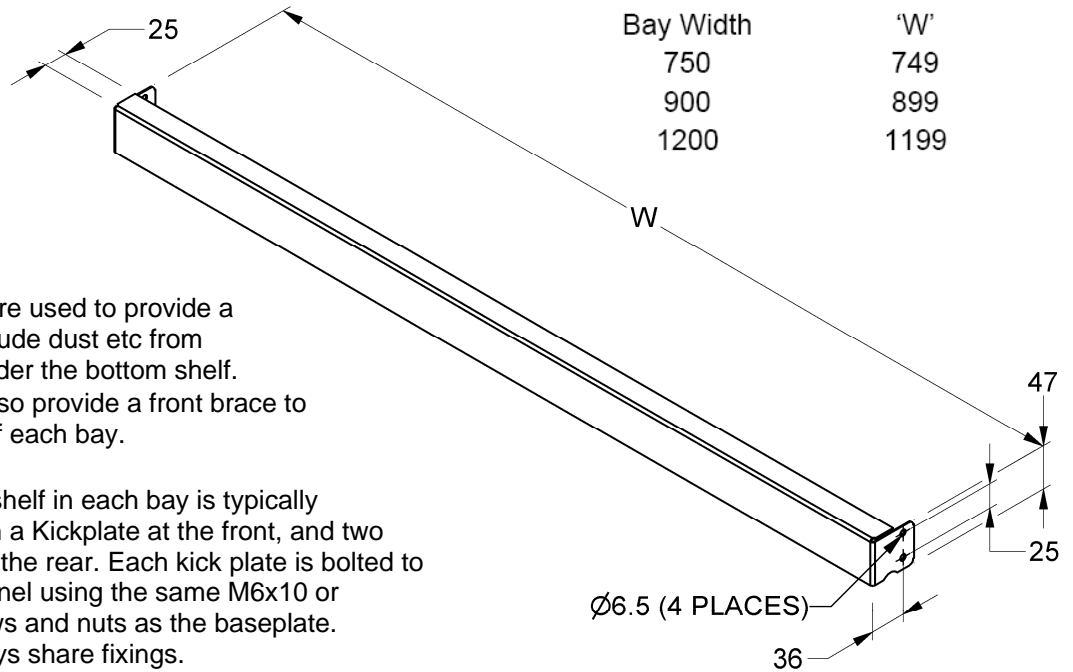

Kick plates are used to provide a cover to exclude dust etc from collecting under the bottom shelf. Kickplates also provide a front brace to the bottom of each bay.

The bottom shelf in each bay is typically supported on a Kickplate at the front, and two shelf clips at the rear. Each kick plate is bolted to the frame panel using the same M6x10 or M6x16 screws and nuts as the baseplate. Adjoining bays share fixings.

Material 1.2mm thick high strength steel
Finish Powder coated

Code	Description	Wt (kg)
202101	KICKPLATE UL 750	0.565
202106	KICKPLATE UL 900	0.666
202116	KICKPLATE UL 1200	0.867

BASEPLATE

Base plates are required at the base of each frame panel, front and rear, to facilitate fixing the frame panel to the floor, and to spread the bay load over a greater floor area.

Baseplates are fixed to the floor using one or two P10x50 concrete anchors.

Refer to Section 3 for conditions where baseplates must be fixed to the floor.

Material 1.9mm thick pre-galvanised high strength steel
Finish Natural (pre-galvanised).

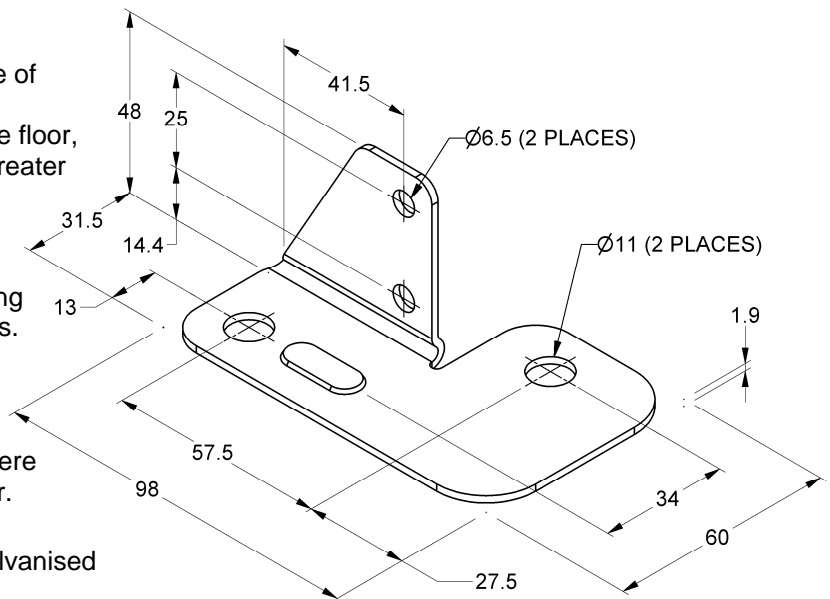

Fixings

Front of Bay	End Bay Frame	Adjoining Bay Frame
	M6 x 10 nut and bolt (2 off)	M6 x 16 nut and bolt (1 off)
Rear Of Bay	Back Clad Bays	Spine Braced Bays
	M6 x 10 nut and bolt (2 off)	M6 x 16 nut and bolt (1 off)

Code	Description	Wt (kg)
202200	BASEPLATE UL 1TIER PGAL	0.118

LEVELLING PLATE

Levelling plates are required to allow the base plates to be packed level when floor is uneven.

A dimple is provided in the plate to locate it correctly into the baseplate other levellers.

Material 1.9mm thick pre-galvanised high strength steel
Finish Natural (pre-galvanised).

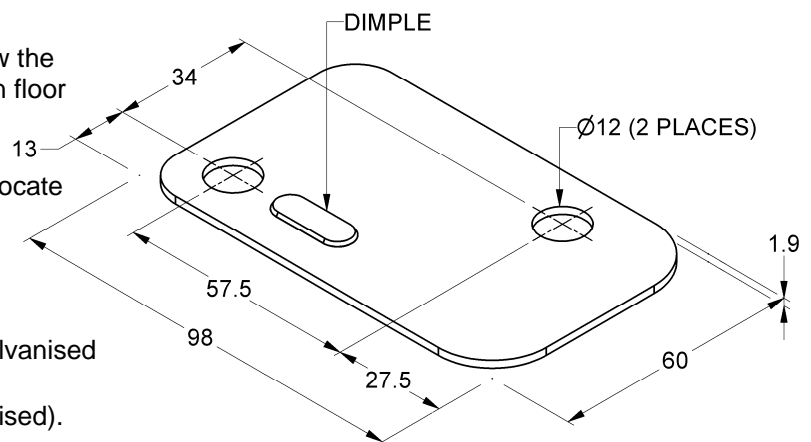

Code	Description	Wt (kg)
202201	LEV PLATE UL 1TIER PGAL	0.088

FASTENERS

M6 x 10 COMB SCREW & NUT ZP

M6 x 10 Comb Screw & Nuts are used to fix the following:

- Back Panels to Frame Panels
- Shelves to Frame Panels (when bolted rather than clipped)
- Kickplates to Frame Panels through one kickplate only
- Baseplates to Frame Panels (non Back braced rear or adjoining type)

Code 151330
Material Mild steel
Weight 3g
Finish Zinc plated



M6 x 16 SET SCREW and M6 NYLOC NUT

M6 x 16 Gr8.8 screw and M6 nyloc nut is used to fix the following:

- Kickplates to Frame Panels for extension bays
- Rear Baseplates to Frame Panels (Back braced)
- Spine Bracing

M6 x 16 Set Screw

Code 120020
Material Mild steel
Weight 10g
Finish Zinc plated

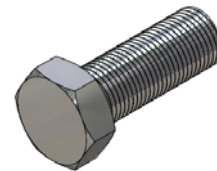

M6 Nyloc Nut

Code 120010
Material Mild steel
Weight 5g
Finish Zinc plated



SCREW 8G X 3/8 (10MM) PAN HD SELF TAPPING

8G x 3/8 Self Tapping Screws are used to fix the following:

Finishing Panels to Frame Panels (4 per finishing panel, in combination with 8g U Nuts)

Finishing Panels to Rear Covers (refer to rear covers for qty)

Code: 160249
Material: Mild steel
Weight: 1g
Finish: Zinc plated



NUT - 8G 'U'

8G 'U' Nuts are used to fix the following:

Finishing Panels to Frame Panels (4 per finishing panel, in combination with 8g screw)

Code: 160250
Material: Spring steel
Weight: 1g
Finish: Zinc plated

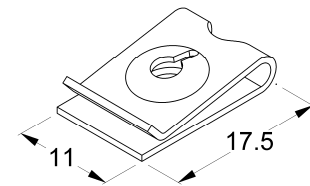

FLOOR FIXING

Floor fixing used to secure the base plates to the floor

Refer to Section 3 of this manual for additional information.

Code	Description	Wt (kg)
120130	SLEEVE ANCHOR SIZE 10 X 75 ZP	0.037
120050	SLEEVE ANCHOR SIZE 10X50 ZP	0.055



REAR COVER

Rear Covers are used to provide a clean finished look to the Single Entry frame panel rear flange.

Material 0.9mm thick high strength steel
Finish Powder coated

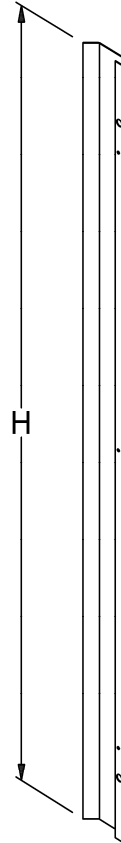
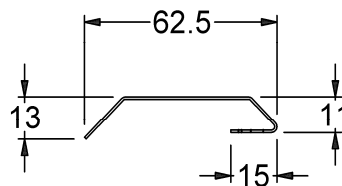

Code	Description	Wt (kg)
202656	REAR COVER UL 1875	0.981
202661	REAR COVER UL 2175	1.138
202666	REAR COVER UL 2400	1.256

Fixing

Rear Covers are attached to finishing panels using 8G x 3/8 Self Tapping Screws at the ends of a run of shelving. Quantity as follows:

1875H	2175H	2400H
3 off	4 off	4 off

When used to cover the rear flange of an intermediate frame, they are clamped between the back panels and no additional fixings are required.

FINISHING PANEL

Finishing Panels are used to provide a clean finished look to the end frame panels of a bay or run of shelving bays.

Material 0.9mm thick high strength steel
Finish Powder coated

Code	Description	Wt (kg)
202456	FINPAN UL PLAIN 1875X300	5.638
202461	FINPAN UL PLAIN 1875X400	7.073
202466	FINPAN UL PLAIN 1875X450	7.791
202476	FINPAN UL PLAIN 1875X600	9.943
202506	FINPAN UL PLAIN 2175X300	6.541
202511	FINPAN UL PLAIN 2175X400	8.205
202516	FINPAN UL PLAIN 2175X450	9.037
202526	FINPAN UL PLAIN 2175X600	11.533
202556	FINPAN UL PLAIN 2400X300	7.217
202561	FINPAN UL PLAIN 2400X400	9.054
202566	FINPAN UL PLAIN 2400X450	9.972
202576	FINPAN UL PLAIN 2400X600	12.727

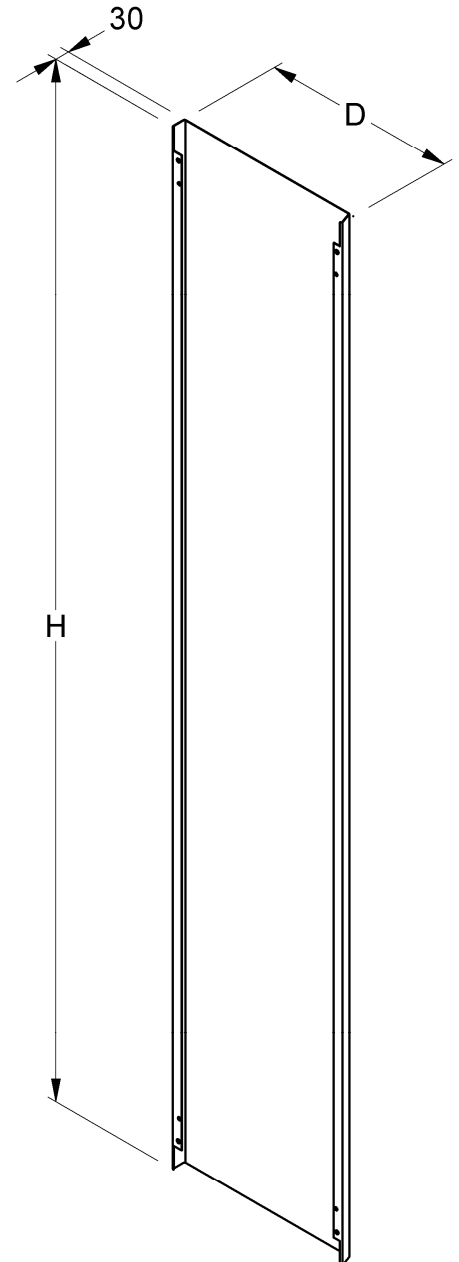

Bay Depth	'D'
300	307
400	407
450	457
600	607

Blank

SECTION 3

DESIGNERS REFERENCE

DEFINITIONS

To eliminate possible of confusion, when describing or specifying shelving installations, the following definitions should be used. These apply to all types of shelving installations.

All dimensions should be given as shown below.

Dimensions in the left-to-right (L-R) plane of the unit are expressed as "LENGTH" or "WIDTH".

e.g. W = Bay width
 L = Unit length

Dimensions in the front-to-back (F-B) plane of the unit (D) are expressed as "DEPTH".

Dimensions in the vertical plane are expressed as "HEIGHT" and are relative to the floor level.

e.g. H1, H2, etc. = Height to top of shelf
 H = Unit height

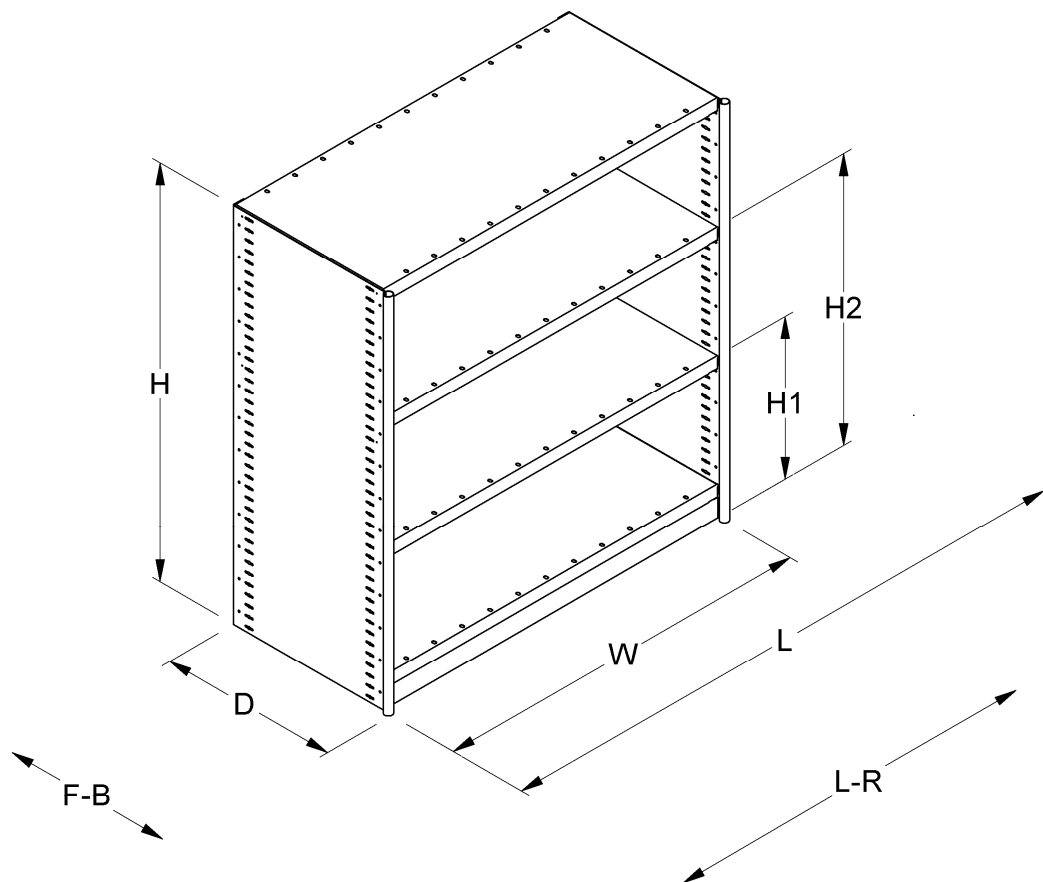

The following definitions describe the most frequently encountered types of unit.

'Clear distance between racks' is the space available for the passage of stores into and out of the racks.

'Vertical clear entry' is the distance between the top surface of one shelf and the underside of the next shelf above. This dimension will be the centre-to-centre spacing of the shelves less the vertical height of the shelf flange (30 mm for ULTIMA CI-80 Steel Shelves).

'Horizontal clear entry' is the distance between the roll posts of the uprights. This dimension will be the overall shelf width less 20 mm.

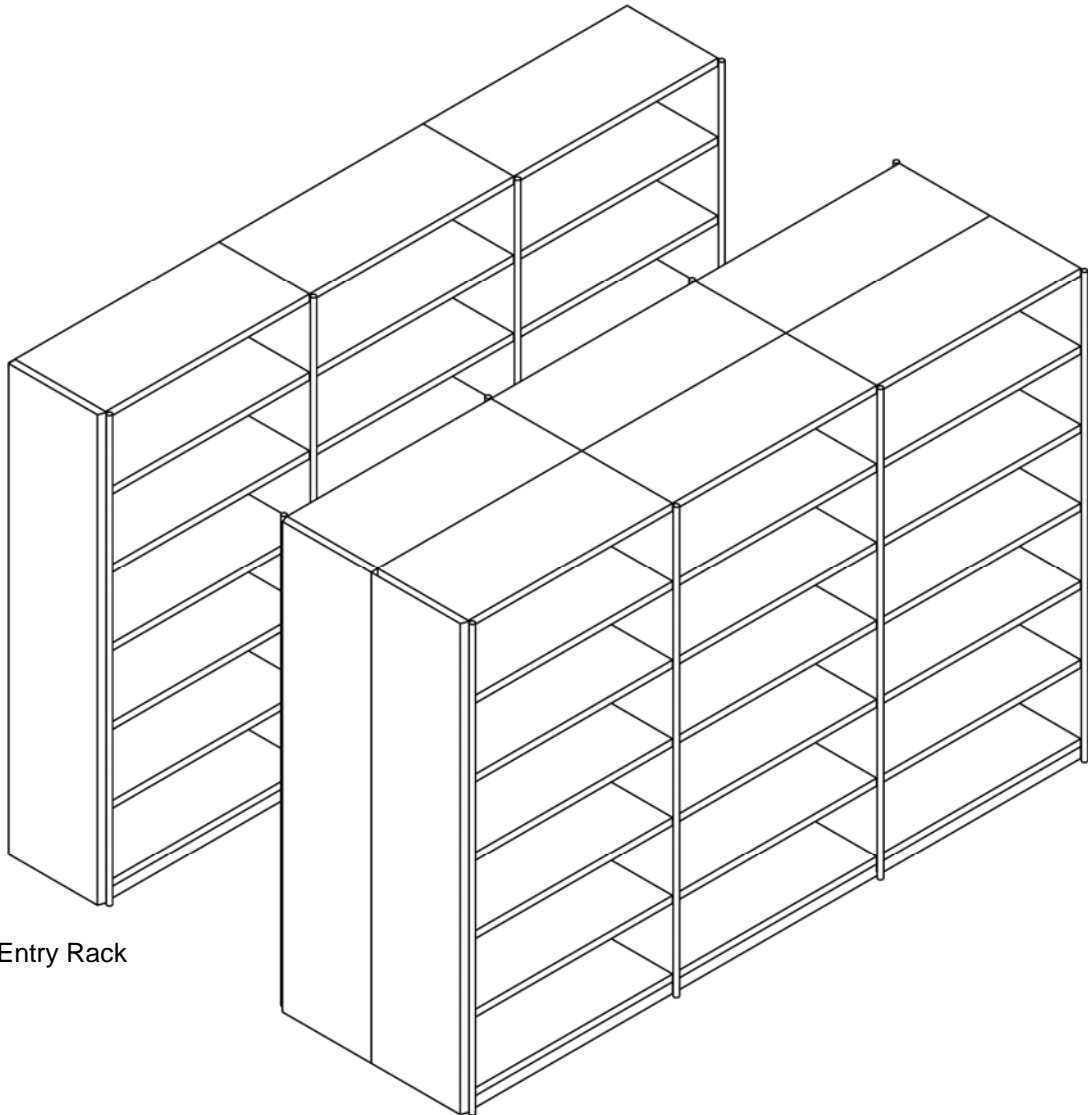

Single Entry Rack

Double Entry Rack

GENERAL LAYOUT

Shelving bays are available in standard heights - 1875, 2175 and 2400 mm.

Bay depths and widths are as per the table below.

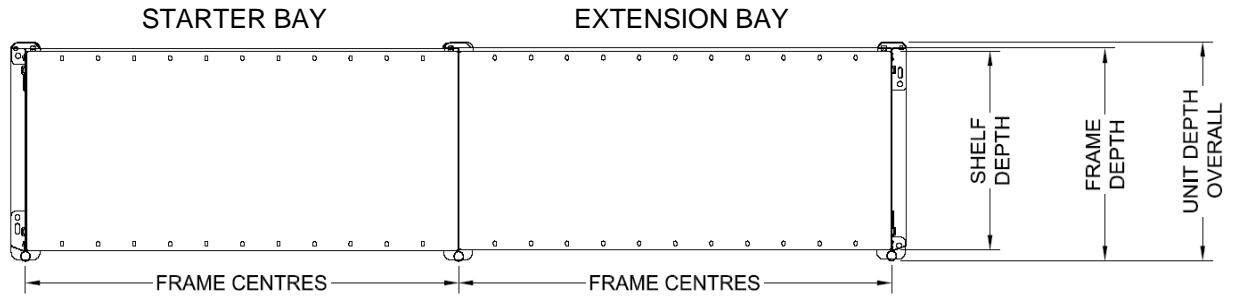

Shelf Depth	300	400	450	600
Frame Depth	328	428	478	628
Unit Depth O.A.	343	443	493	643
Frame Centres	750	900	1200	
Clear Opening	730	880	1180	

NOTE: Overall unit depth includes allowance for base plates and rear cover.

GENERAL DESIGN RULES AND RECOMMENDATIONS

- The shelves are adjustable on a 25 mm module.
- The top shelf, positioned at the very top of every shelving bay must always be bolted.
- The kick plates are bolted each side to the frame panels. If kick plates are not used the bottom shelves must be bolted three slots up from the bottom of the panel.
- Base plates must be used at the front and rear to give a firm level support for the roll post and back flange of the frame panel.
- Back panels or spine bracing are always fitted to the outside of the bay on single entry racks, and between the frames of a double entry rack. The panels are bolted on each corner plus intermediate bolts at 300mm maximum centres.

ALLOWANCE FOR CREEP

Left to Right

Each bay could be approximately 2mm longer than the shelf. In addition to this, when calculating the overall length of a rack, add 20mm to account for the roll posts (60mm if finishing panels are used), therefore, the overall creep a rack will be:

Number of bays x (Bay Width + 2) + 60 or 20 mm

Eg. 2 off 1200 bays with no finishing panels.

$$\begin{aligned}\text{Bay length creep} &= 2 \times (1200+2) + 20 \\ &= 2424\text{mm overall}\end{aligned}$$

Front to Back

Each bay will be approximately 30 mm deeper than the nominal shelf depth, therefore, the overall depth of a rack will be:

Single entry = shelf depth + 30 mm

Double entry = 2 x shelf depth + 60 mm

OR

Shelf depth bay 1 + shelf depth bay 2 + 60 mm,
for double entry bays with different shelf depths.

Eg. A 300/400 Double entry

$$\begin{aligned}\text{Bay Depth Creep} &= (300+1)+(400+1) +60 \\ &= 762\text{mm overall.}\end{aligned}$$

INSTALLATION PLANNING

General

When the preliminary investigation has been completed and all the necessary details regarding the required function of the installation, the physical nature of the site, items to be stored, types and sizes of files, handling methods, etc., have been obtained, the first design stage is to select the most suitable size of shelf.

Shelf Layout Plan

Several aspects must be considered before a shelf width can be selected as being the most satisfactory. In most cases, an acceptable layout can be determined by the layout of the items to be stored. This size is then modified depending on the available area or user capabilities. An alternate method is to layout the shelving to the maximum available storage area.

The prospective user should always be given details of the proposed layout of goods on the shelf in order that he may adopt and maintain that system. This information should be specified in the quotation and possibly amplified by means of a drawing.

Plan Bay Layouts

Generally, as the shelf depth increases the storing capacity increases. The required gangway between runs of shelving needs to be no larger for a 600 mm shelf than for a 300 mm shelf, therefore, the proportion of gangway space decreases as the shelf depth increases. The unit cost per item will decrease as the shelf depth increases. The disadvantage of a deep shelf is the increased problems in identification, selection, stock rotation, etc.

There are few standards that can be laid down for the use when investigating the plan layout of shelving. Each situation must be assessed individually by means of a series of trial layouts to determine the best solution to satisfy the required function (increased capacity; easier handling, etc.).

Amongst the more obvious factors to be considered are:

Aisles – Aisles must provide access to the loading face of every bay and must be interconnected throughout the installation to reduce the handling distance. The focal point for aisles must be the doorways through which entry to or exit from the area is made. Aisles must be wide enough to allow for the following in any scheme:

- The passage of the personnel when carrying the largest of the stored items.
- The handling of stores into and out of the shelving.
- The use of handling aids such as ladders and steps, and also the passage of trolleys and barrows, etc.
- The identification of stores at the highest storage level.

Aisles will not generally be less than 750 mm wide and may need to be up to 1200 mm or more if trolleys are to be used. In some larger storage installations the Aisles may have to conform to fire authority regulations. This should be checked at the pre-quote stage.

Access – Access must be maintained, not only to obvious features, such as doorways, but also to windows, light switches, power points, taps, etc. Many of these features are not shown in the pre-quote information details, therefore, these must be checked prior to offering to install a storage scheme.

Obstructions – Obstructions will feature in most areas set aside for storage. Very few sites will be clear of columns, buttresses, pipes, manholes and other permanent obstructions. Dependent upon the main function of the installation, it must be decided whether to:

Plan the shelving away from the obstruction, or build the shelving around the obstruction, making full use of the available space but at an increased cost.

In either case, if obstructions are planned to be in the gangway areas, then the gangway width must be increased sufficiently to allow access.

From a general viewpoint, the most satisfactory scheme will be one which:

- Stores goods in the minimum frame width
- Uses the deepest shelf on which stores can be economically arranged to make full use of the shelf area.
- Has the picking faces of the shelving arranged to run parallel with longer dimension of the storage area
- Has single entry shelving adjacent to the perimeter of the area and double entry or back-to-back shelving occupying the centre
- Has transverse Aisles connecting the main Aisles by dividing the runs of shelving at a maximum of 10 metre centres. Longer units will involve more walking distance but may be acceptable if increased storage capacity is a main criteria for the installation.

Individual Bay Shelf Layout

The next planning stage, after determining a preferred plan layout, is the consideration of the vertical spacing of the shelves, the number of shelves per bay and thus, the height of the rack. The overall height of the rack may be limited by a physical restriction (roof trusses, ceilings etc.) or by an arbitrary restriction set by handling the identification requirements.

The vertical spacing of the shelves will be dependent upon the acceptable stacking height of the stores. Greater economy of cost and space utilisation will be achieved if packages can be stacked several high on each shelf. Restrictions must again be imposed here to allow for the following aspects:

- The prevention of crushing the lower packages
- The stability of the stack
- Handling and identification
- The maximum safe load on the shelf.

The spacing of the shelves, which must be in increments of 25 mm, will be the sum dimension of the stacked height of items, PLUS 30 mm shelf thickness, PLUS 40 mm recommended clearance between the top of the stores and the underside of the next shelf above.

ULTIMA CI-80 installation presents little difficulty from a basic design aspect, however, it is important to give due consideration to the site, layout planning and construction requirements to ensure a customer focused result.

BACK BRACING

Back bracing is fitted to the outside of the frames, when no back cladding is requested on single sided racks, and to the inside of the bay on double entry racks. It is always fixed through the bottom and top frame panel rear flange holes (as shown below). For double entry racks, extra bolt levels at 500 mm centres are required through both flanges to provide added rigidity. All double entry bays should be bolted back to back in the open and diagonally braced bays.

Bay Width	Brace type		
	A (H.C.)	B (H.C.)	C (H.C.)
750	1152	1399	1596
900	1251	1482	1669
1200	1475	1675	1843

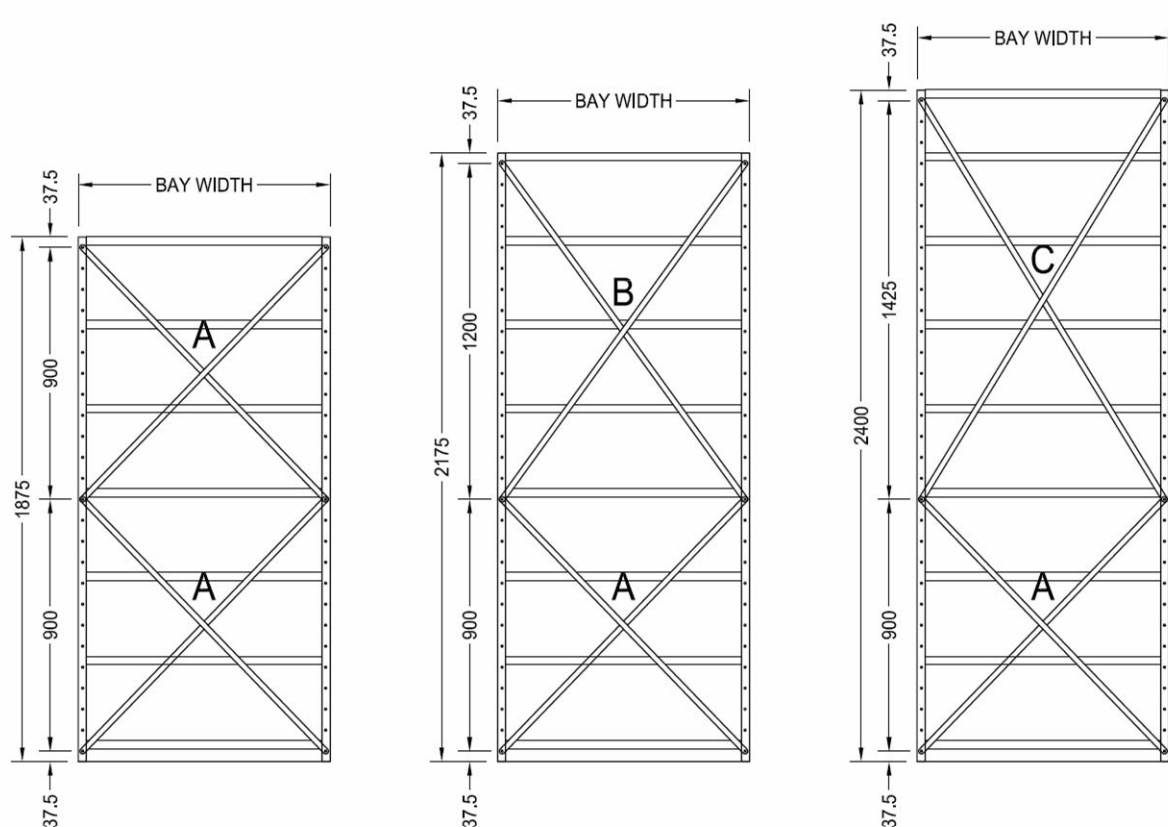

When using back bracing, the following minimum frequency applies:

- | | |
|-----------------|--|
| 1 bay | - bracing in 1 st bay |
| 2 bays | - bracing in 1 st bay |
| 3 bays | - bracing in each end bay. |
| 4 bays | - bracing in each end bay. |
| 5 bays | - bracing in each end bay, plus 3 rd bay |
| 6 bays | - bracing in each end bay, plus 3 rd bay |
| 7 bays | - bracing in each end bay, plus 4 th bay |
| 8 bays | - bracing in each end bay, plus 4 th bay |
| 9 bays | - bracing in each end bay, plus 5 th bay |
| 10 bays | - bracing in each end bay, plus 4 th and 7 th bay |
| 11 bays or more | - bracing in each end bay, plus additional bracing such that no more than 2 consecutive bays are unbraced. |

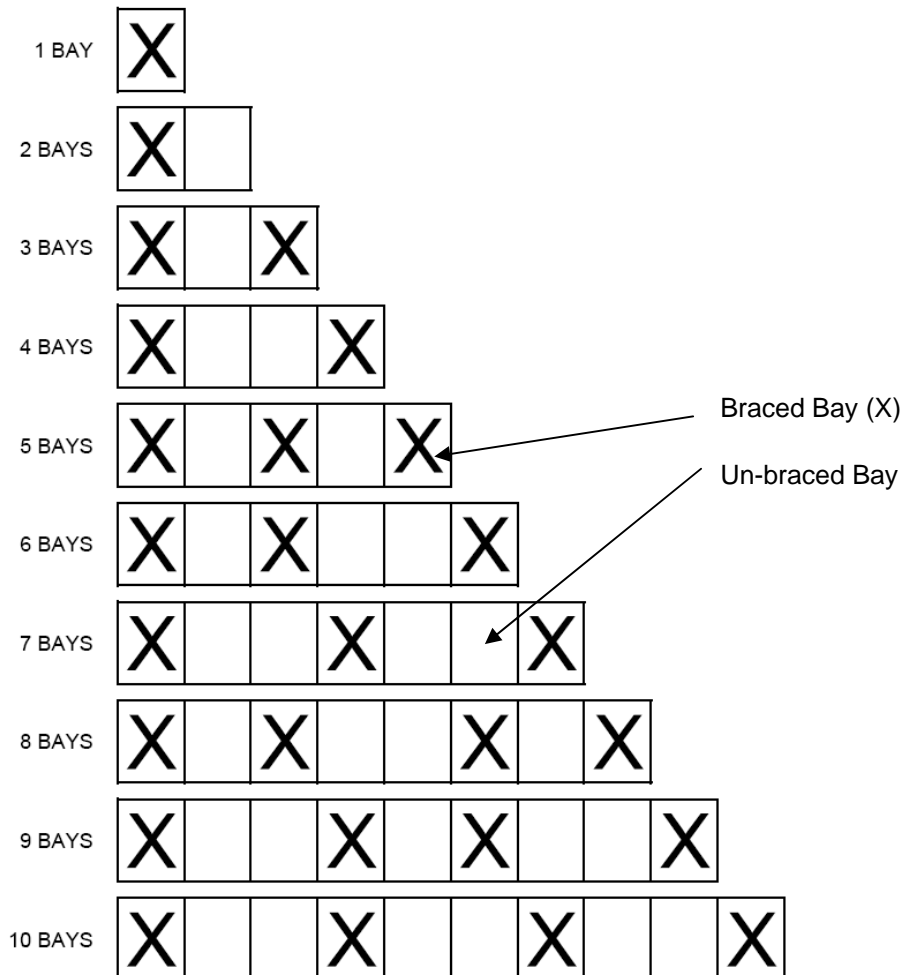

 **Note:**

When assembling the shelving bays, ensure the frame panel rear flanges are orientated towards each other on bays requiring back bracing.

RACK STABILITY AND FIXING

A height to depth ratio limitation is necessary to prevent a free-standing rack from being unstable. The following height to depth ratios should be bolted down and applies to bays with steel back panels or back bracing. The customer must be advised that the unit could tip over under certain conditions – e.g. if a full filing drawer pulled out of an empty unit if the unit is not adequately fixed to the floor or a situation where the shelving is near a door that is exposed to stiff wind gusts.

Height to depth ratios which require fixing to the floor:

6:1 height to depth ratio and above

- ie: single entry 300mm deep x 1875mm and higher.
- single entry 400mm deep x 2400mm and higher.



Note:

- *Single entry bays of height/width greater than 8:1 should also be securely tied back at the top of the bay over the aisle to a double entry run.*

4:1 height to depth ratio when applying loads outside the plan perimeter of the bays, (e.g. drawers)

- ie: single entry 300mm deep x 1200mm and higher
- single entry 400mm deep x 1600mm and higher
- single entry 600mm deep x 2400mm and higher

Concrete anchors should be used in all situations requiring floor fixings. This fixing should be embedded into concrete a minimum of 50mm.



Note:

- *Local safety standards can cause these ratios to differ.*
- *Base plates permit a maximum 10mm diameter drill or bolt access.*
- *Only shelving on concrete floors is covered within this manual. For other applications contact Technical Services*

Floor Fixing Requirement

Shelving with Back Panels

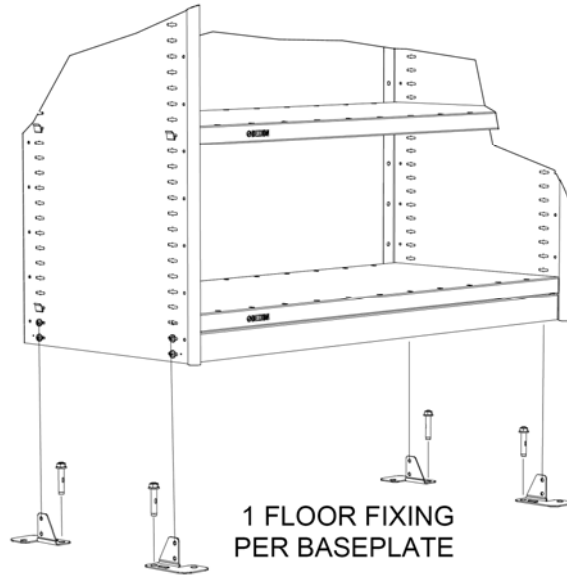

Shelving with Spine Bracing

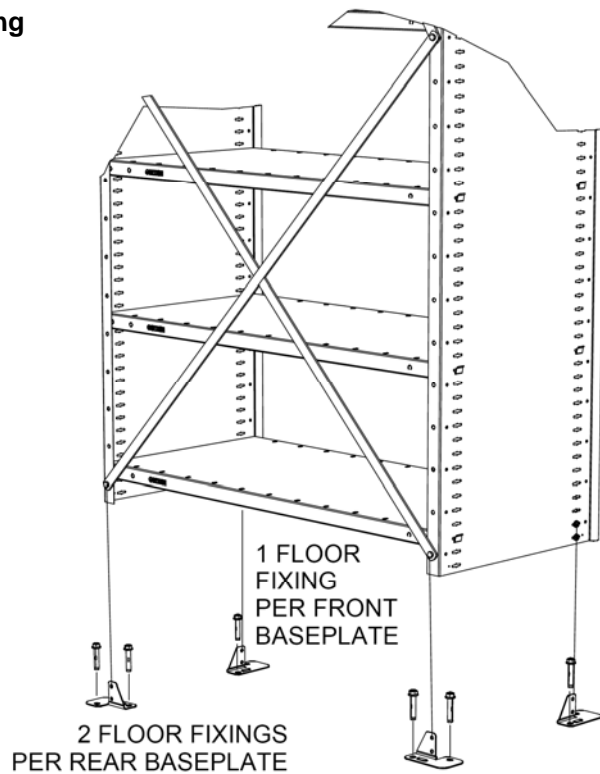

Note:

The rear base plate orientation differs for spine braced bays. See Section 4 for Spine Brace assembly details. See Section 1 for Floor Fixing component details.

FLOOR LEVELLING

The maximum permissible rack vertical 'out-of-plumb' to be 1/200 - i.e. a 2175 mm high cabinet is allowed to be 11 mm out at the top. Levelling plates must be used if imperfect floor levels exceeding the above are encountered.

Fixing the shelving to the floor is recommended where levellers are used in conjunction with uneven or sloping floors.

FLOOR QUALITY

A careful study of the floor and its loading capability should be carried out by the customer to ensure suitability for the proposed installation.

SAFETY SIGNAGE

A notice, as shown below, must be placed on the back panel inside the unit at approximately 1500 mm high on all single entry units:

This unit may be unstable when not loaded. To ensure that the unit is stable when loaded - always load the bottom shelves first.

LOADING INFORMATION

SHELVES

Shelves have the following maximum load rating. These ratings are based on a uniformly distributed load. (UDL)

PLAIN SHELVES

	Shelf Depth			
Bay Width	300	400	450	600
750	130 kg	130 kg	115 kg	115 kg
900	130 kg	130 kg	115 kg	115 kg
1200	80 kg	80 kg	80 kg	100 kg
Mat. Thickness	0.75			0.95

STIFFENED SHELVES

	Shelf Depth			
Bay Width	300	400	450	600
750	240 kg	240 kg	200 kg	200 kg (2)
900	240 kg	240 kg	200 kg	200 kg (2)
1050	170 kg	170 kg	170 kg	190 kg (2)
1200	170 kg	170 kg	170 kg	190 kg (2)
Mat. Thickness	0.75			0.95
Shelf Stiffeners	1 x shelf stiffener at <u>front of shelf</u>			2 stiffeners

BAYS WITH BACK BRACING

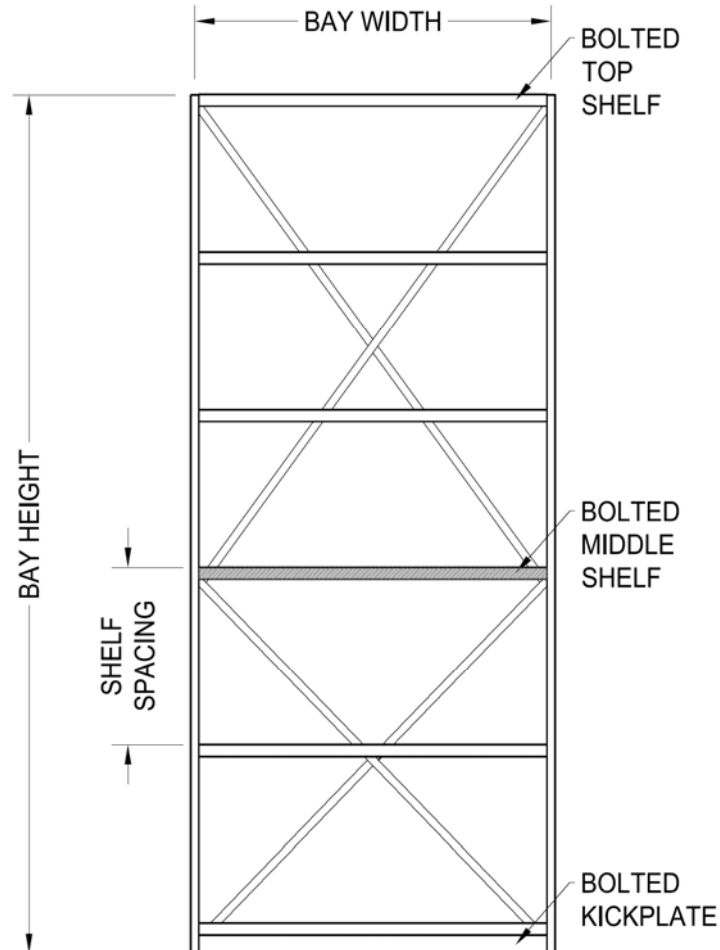

BACK BRACING BAY LOAD TABLE

Shelf Spacing	Shelf Depth			
	300	400	450	600
400mm Maximum	700 kg	700 kg	900 kg	900 kg
600mm Maximum	500 kg	500 kg	700 kg	700 kg
Frame Material Thickness	0.75		0.95	

The above figures assume the following:

- Bays have a kick plate and a top shelf bolted in position.
- Bays also have a middle shelf (closest to spine bracing node point) bolted in position.
- Bays have back bracing correctly fitted as detailed in this manual.
- Bays have base plates correctly fitted, and are levelled.

BAYS WITH BACK CLADDING

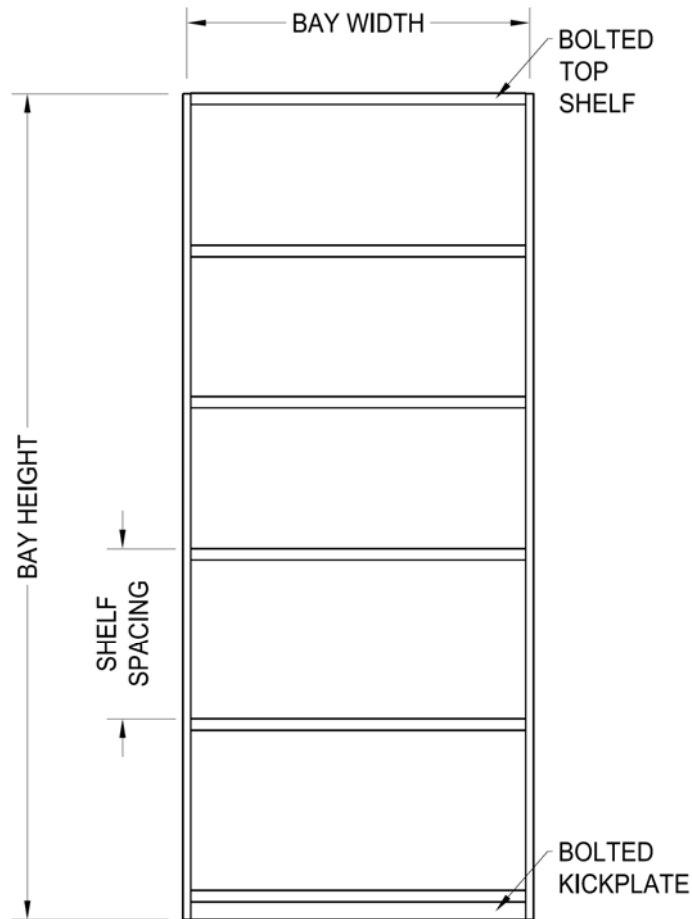

BACK CLADDING BAY LOAD TABLE

Shelf Spacing	Shelf Depth			
	300	400	450	600
400mm Maximum	700 kg	700 kg	900 kg	900 kg
600mm Maximum	500 kg	500 kg	700 kg	700 kg
Frame Material Thickness	0.75		0.95	

The above figures assume the following:

- Bays have a kick plate and a top shelf bolted in position.
- Bays have back panels correctly fitted, and bolted at maximum 300mm centres.
- Bays have base plates correctly fitted, and are levelled.

BAYS WITH BACK CLADDING AND BOLTED MIDDLE SHELF

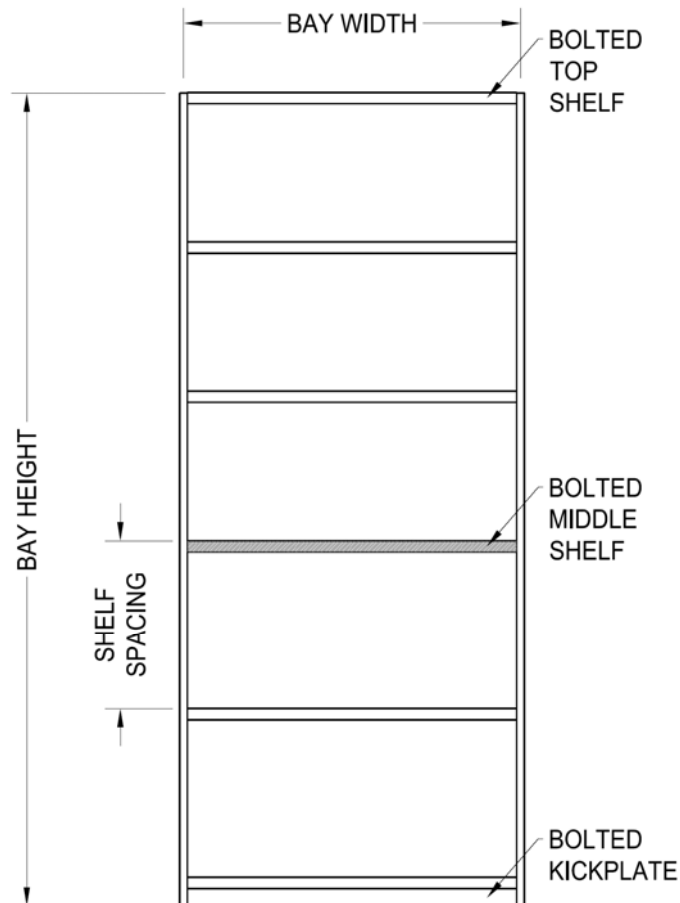

BACK CLADDING WITH BOLTED MIDDLE SHELF BAY LOADS

Shelf Spacing	Shelf Depth			
	300	400	450	600
400mm Maximum	800 kg	800 kg	1035 kg	1035 kg
600mm Maximum	575 kg	575 kg	800 kg	800 kg
Frame Material Thickness	0.75		0.95	

The above figures assume the following:

- Bays have a kick plate and a top shelf bolted in position.
- Bays also have a middle shelf (between 800 & 1200 from bottom) bolted in position.
- Bays have back panels correctly fitted, and bolted at maximum 300mm centres.
- Bays have base plates correctly fitted, and are levelled.

STANDARD BAY CONSTRUCTION TIMES

Standard Bay Configuration	STR / EXN	Bay Height	Shelf Depth	SE / DE	Est. Labour
----------------------------	-----------	------------	-------------	---------	-------------

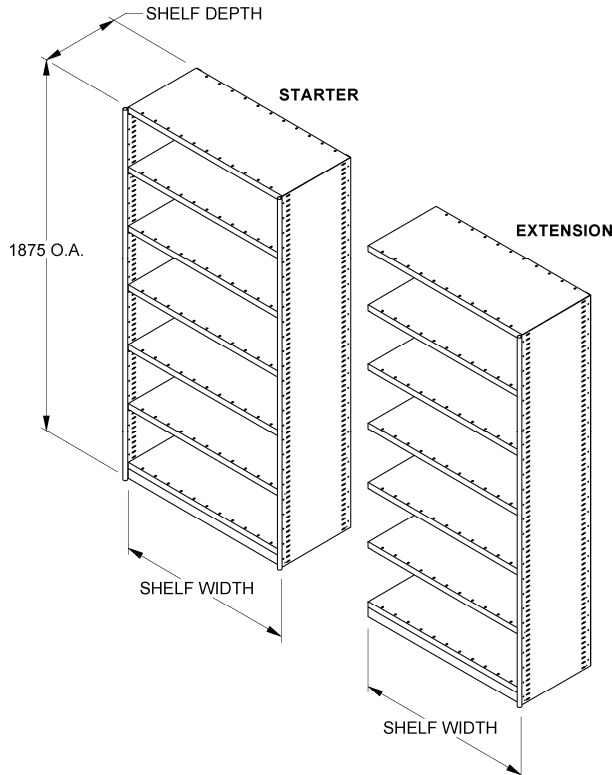

STR	1875	300 - 600	SE	45min
EXN	1875	300 - 600	SE	40min
STR	1875	300 - 600	DE	1 hr
EXN	1875	300 - 600	DE	1 hr

Standard Bay Configuration	STR / EXN	Bay Height	Shelf Depth	SE / DE	Est. Labour
----------------------------	-----------	------------	-------------	---------	-------------

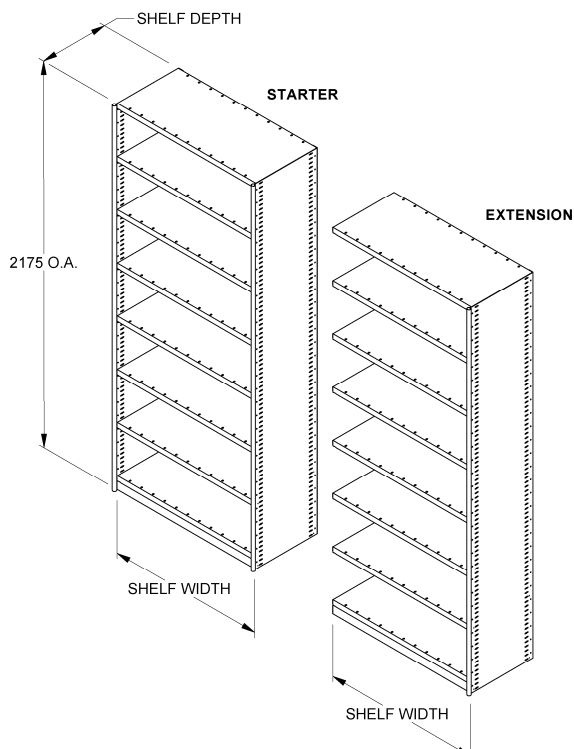

STR	2175	300 - 600	SE	50min
EXN	2175	300 - 600	SE	40min
STR	2175	300 - 600	DE	1 hr
EXN	2175	300 - 600	DE	1 hr

Standard Bay Configuration	STR / EXN	Bay Height	Shelf Depth	SE / DE	Est. Labour
----------------------------	-----------	------------	-------------	---------	-------------

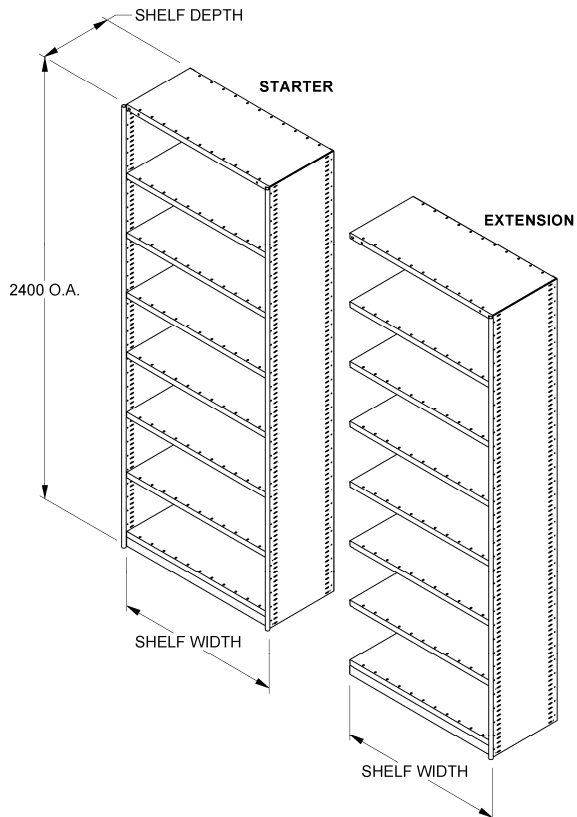

STR	2400	300 - 600	SE	1 hr
EXN	2400	300 - 600	SE	50min
STR	2400	300 - 600	DE	1 hr
EXN	2400	300 - 600	DE	1 hr